

# INTEGRATED RING BIT SYSTEM, LARGE

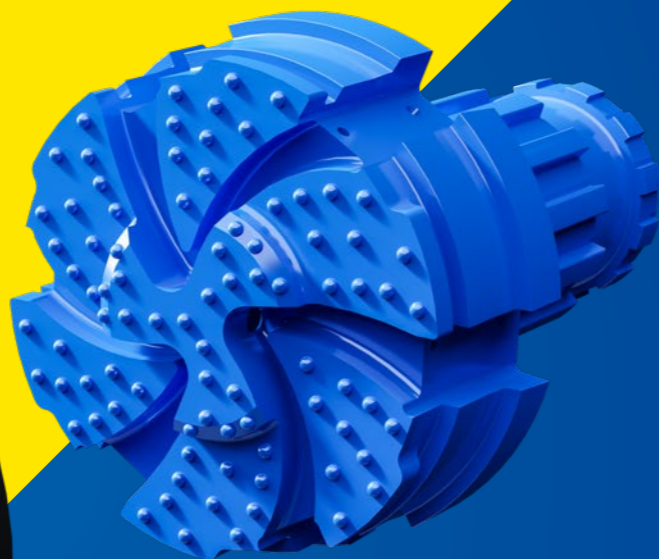

**Integrated ring bit systems**, divided into small and large designs, are designed for drilling end-bearing piles through overburden into bedrock. The system can drill straight and inclined piles through boulders and rock layers and it easily manages situations where the bedrock itself is inclined.

The heavy-duty ring bit is integrated into casing shoe, which makes it safe to drill in loose ground and over water. The large size allows for double-shoulder design.

### MAIN APPLICATIONS

- End-bearing piles
- Pileings with sacrificed casings, which have no large ID ring bit requirements
- Pipe walls, king piles

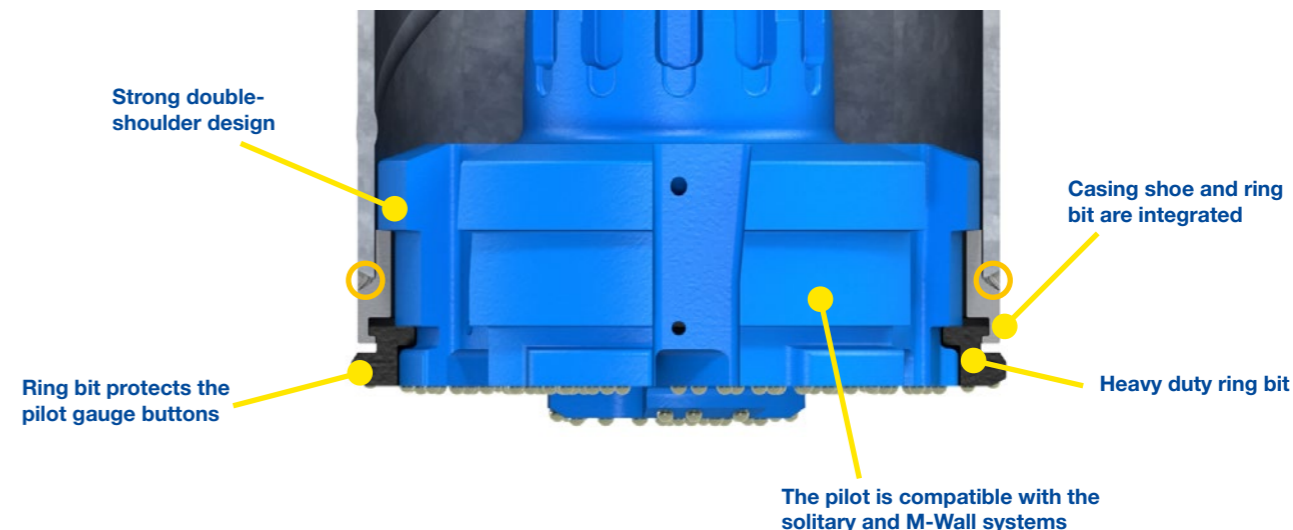

○ = Welding spot

System is available from 323 to 1 524 mm casings and for all major shank designs.

System product code	Casing OD		Max wall		Ring bit ID		Ring bit OD		Pilot bit OD		Recommended hammer
	mm	inch	mm	inch	mm	inch	mm	inch	mm	inch	
I323-14.2-240	323.9	12.74"	14.2	0.56"	240	9.45"	335	13.19"	291	11.46"	MP100-MC
I339-14.2-255	339.7	13.37"	14.2	0.56"	255	10.04"	350	13.78"	308	12.13"	MP100-MC
I355-14.2-270	355.6	14"	14.2	0.56"	270	10.63"	367	14.45"	324	12.76"	MP100-MC
I406-16-318	406.4	16"	16	0.63"	318	12.52"	418	16.46"	370	14.57"	MP120-MC
I457-16-369	457.2	18"	16	0.63"	369	14.53"	469	18.46"	420	16.54"	MP120-MC
I508-16-422	508	20"	16	0.63"	422	16.61"	520	20.47"	471	18.54"	MP150-MC
I559-16-470	558.8	22"	16	0.63"	470	18.50"	571	22.48"	521	20.51"	MP150-MC
I610-16-502	609.6	24"	16	0.63"	502	19.76"	622	24.49"	572	22.52"	MP180-MQ
I660-16-545	660.4	26"	16	0.63"	545	21.46"	675	26.57"	615	24.21"	MP180-MQ
I711-16-610	711.2	28"	16	0.63"	610	24.02"	735	28.94"	675	26.57"	MP240-MQ
I762-20-655	762	30"	20	0.79"	655	25.79"	785	30.91"	715	28.15"	MP240-MQ
I813-20-700	812.8	32"	20	0.79"	700	27.56"	830	32.68"	766	30.16"	MP240-MQ
I863-20-750	863.6	34"	20	0.79"	750	29.53"	880	34.65"	815	32.09"	MP240-MQ
I914-20-800	914.4	36"	20	0.79"	800	31.5"	930	36.61"	866	34.09"	MP240-MQ
I1016-20-880*	1 016	40"	20	0.79"	880	34.65"	1 032	40.63"	966	38.03"	MP340
I1066-20-930*	1 066.8	42"	20	0.79"	930	36.61"	1 086	42.76"	1 014	39.92"	MP340
I1219-20-1080*	1 219.2	48"	20	0.79"	1 080	42.52"	1 240	48.82"	1 168	45.98"	MP340
I1321-22-1150*	1 320.8	52"	22	0.87"	1 150	45.28"	1 344	52.91"	1 247	49.09"	MP400
I1422-22-1250*	1 422.4	56"	22	0.87"	1 250	49.21"	1 446	56.93"	1 348	53.07"	MP400
I1524-22-1340*	1 524	60"	22	0.87"	1 340	52.76"	1 548	60.94"	1 462	57.56"	MP400

\*Large diameter systems can be engineered based on the specific customer requirements.